

TM(J)G-325 SERIES

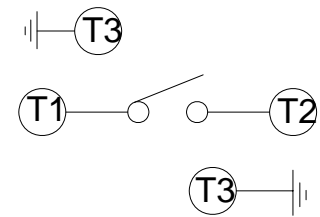

**DIMENSION**

**TMG-325**

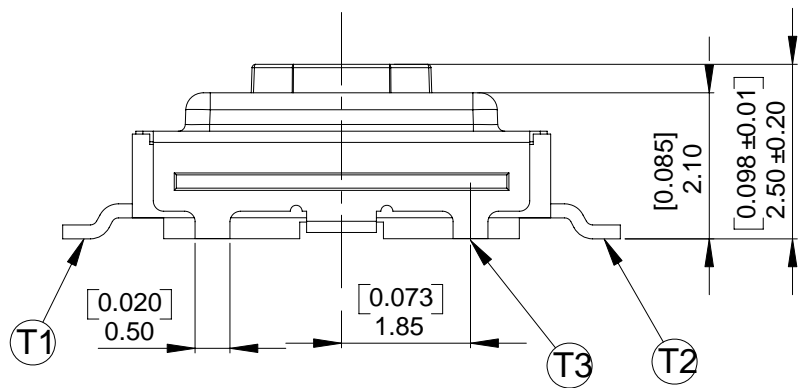
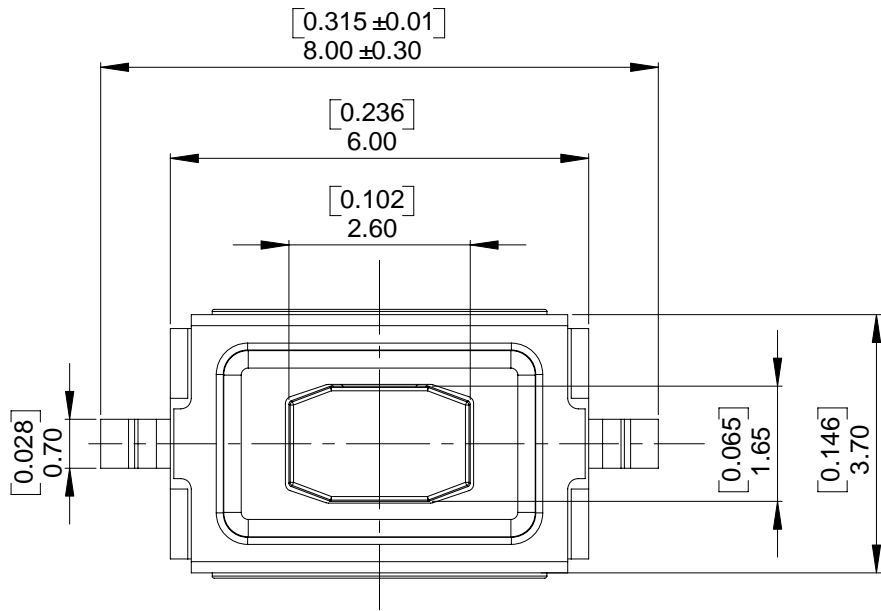

**CIRCUIT DIAGRAM**

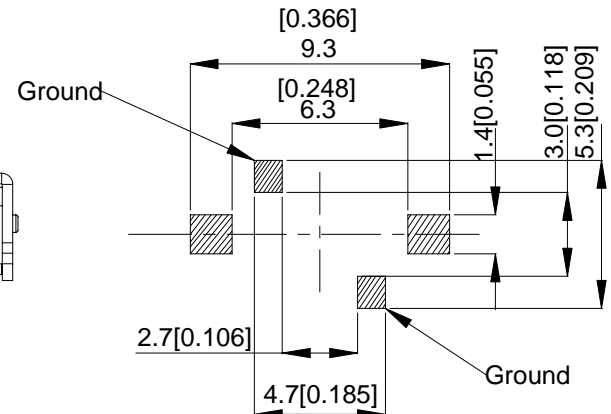

**P.C.B. LAYOUT**

General Tolerance : ±0.2mm

**TJG-325**

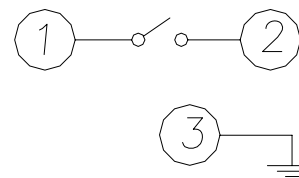
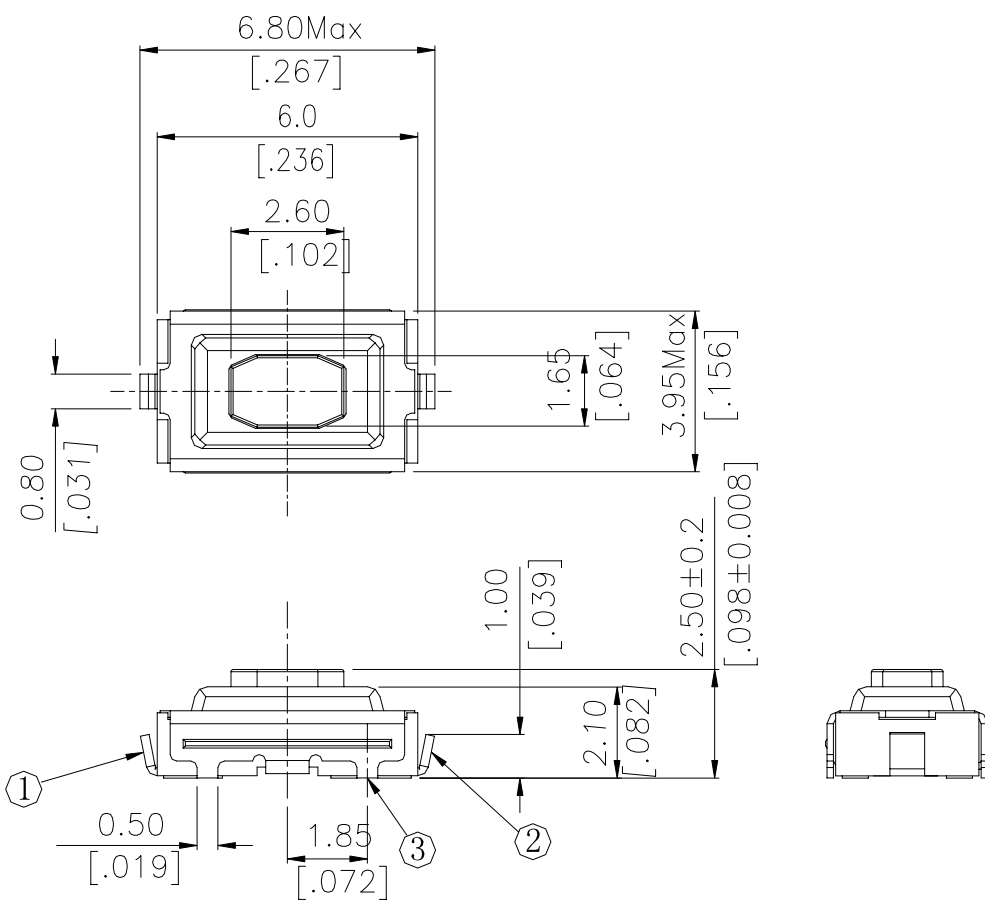

**CIRCUIT DIAGRAM**

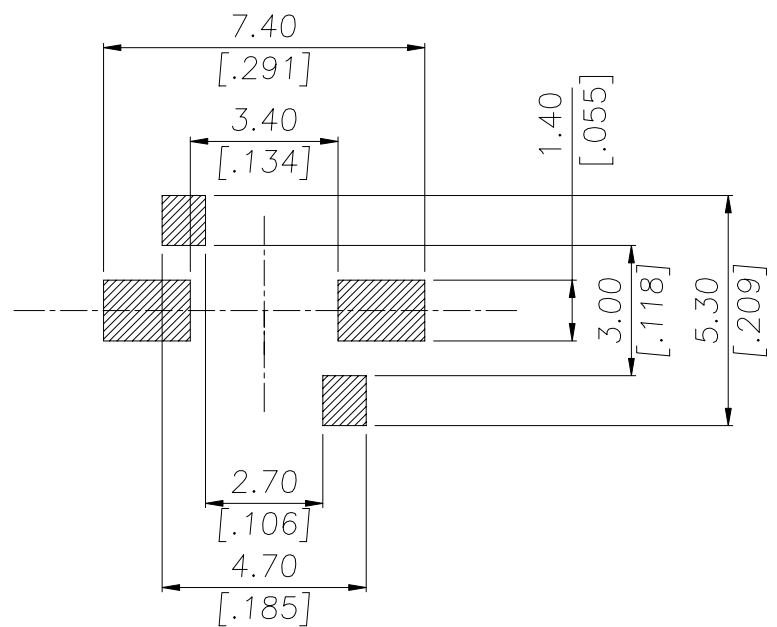

**P.C.B. LAYOUT**

General Tolerance : ±0.2mm

## HOW TO ORDER

T □ G - 3 □ □ □ - □ - □

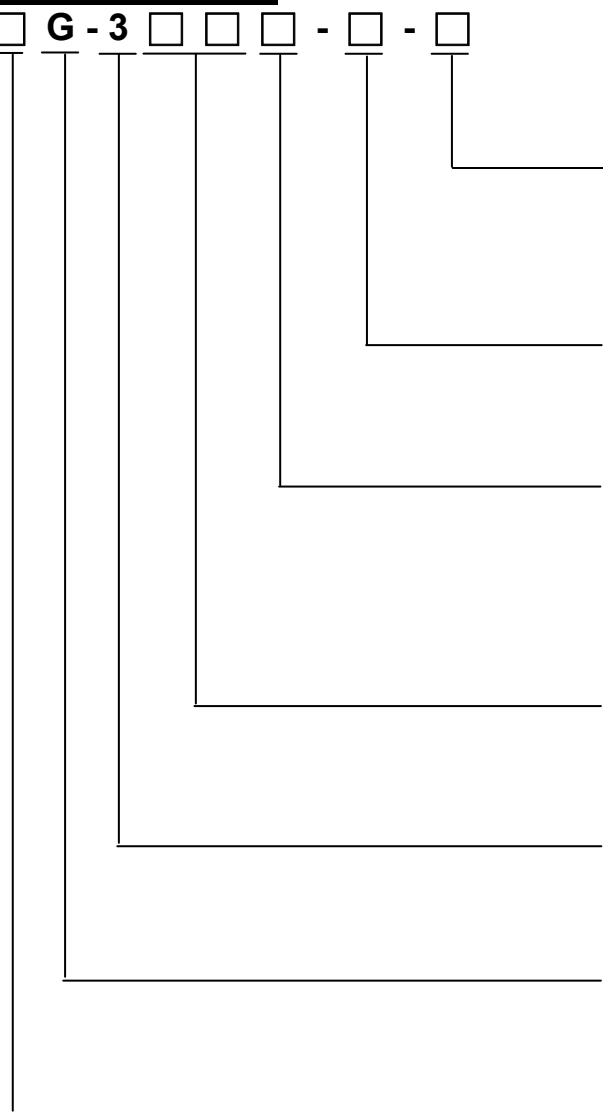

### Package Style :

□ = Regular  
T/R = Tape & Reel

### Solder :

V = Lead Free

### Operating Force :

N = 160gf, Brown  
R = 260gf, Red  
< Brown Available Now)

### Total Height :

25 = 2.5mm

### Prod. Size :

3 = 3.5X6

### Prod. Series :

G = With Ground Terminal

### Termination Type :

M = Gull Wing  
J = J Bend

## SPECIFICATION

### △ MECHANICAL

Operation Force; 160±50gf Brown(N)  
Stroke: 0.25+0.2/-0.1mm  
Operation Temperature Range: -25°C to +70°C  
Storage Temperature Range: -30°C to +80°C

### △ ELECTRICAL

Electrical Life: 50,000 cycles for 160gf.  
Rating: 50mA, 12VDC  
Contact Resistance: 100mΩ max.  
Insulation Resistance: 100MΩ min. at 500 VDC  
Dielectric Strength: 250VAC/1 minute  
Contact Arrangement : 1 pole 1 throw.

## MATERIAL

- △ COVER : Nickel silver
- △ CONTACT DISC : Stainless with silver cladding
- △ TERMINAL : Brass with silver plated
- △ BASE : UL94V-0 Nylon High-Temp Thermoplastic  
COLOR : Black
- △ STEM : UL94V-0 Nylon High-Temp Thermoplastic  
COLOR : Brown ( 160g ) Red (260g)
- △ TAPE : Teflon

## SOLDERING PROCESS

### △ HAND SOLDERING : Use a soldering iron of 30 watts,

Controlled at 608°F (320°C) approximately 2 seconds while applying solder.

### △ REFLOW SOLDERING : When applying reflow soldering,

the peak temperature or the reflow oven should be set to 260°C max.

### △ Temperature Profile :

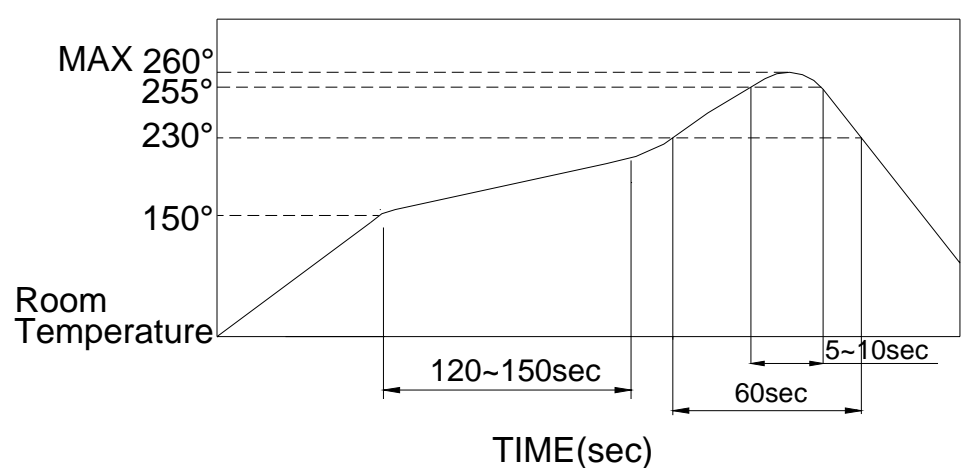

# PACKING

REEL

Part Number	Number Per Tube	Number Per Reel
TMG-325	-	2800
TJG-325	-	2800

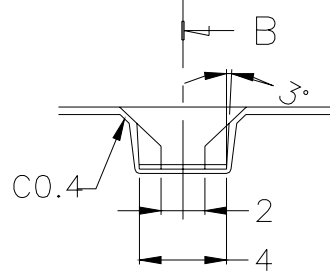
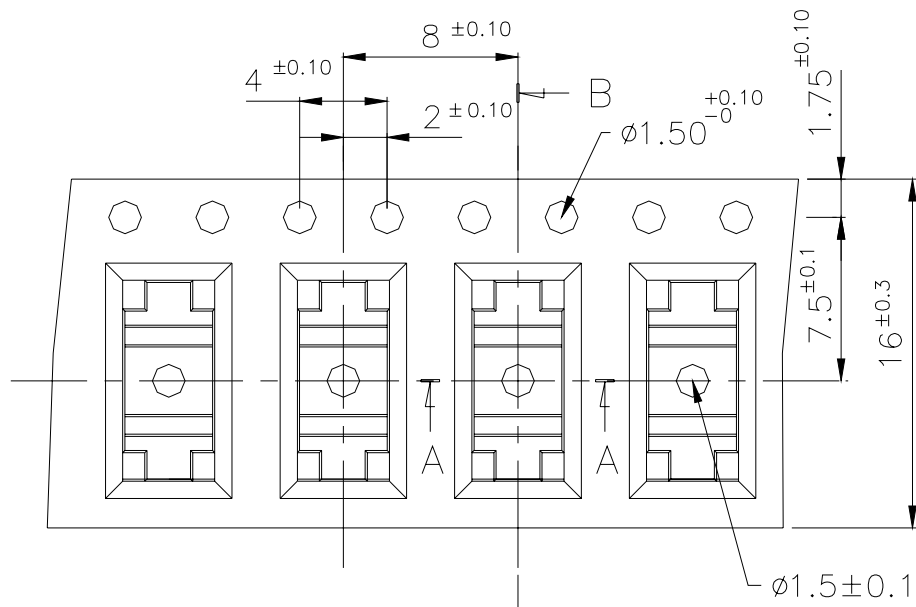

A-A Section

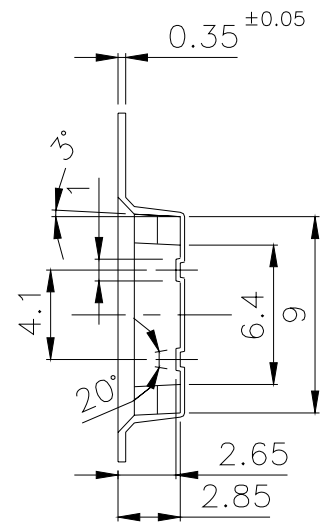

B-B Section

General Tolerance :  $\pm 0.1\text{mm}$