

SPECIFICATION FOR APPROVAL

REF. :

PROD. NAME	SMD Power Inductor	ABC'S DWG NO.	SB5014□□□□L□-□□□		
		REV.	20130208-A	PAGE	1

I . Configuration and dimensions :

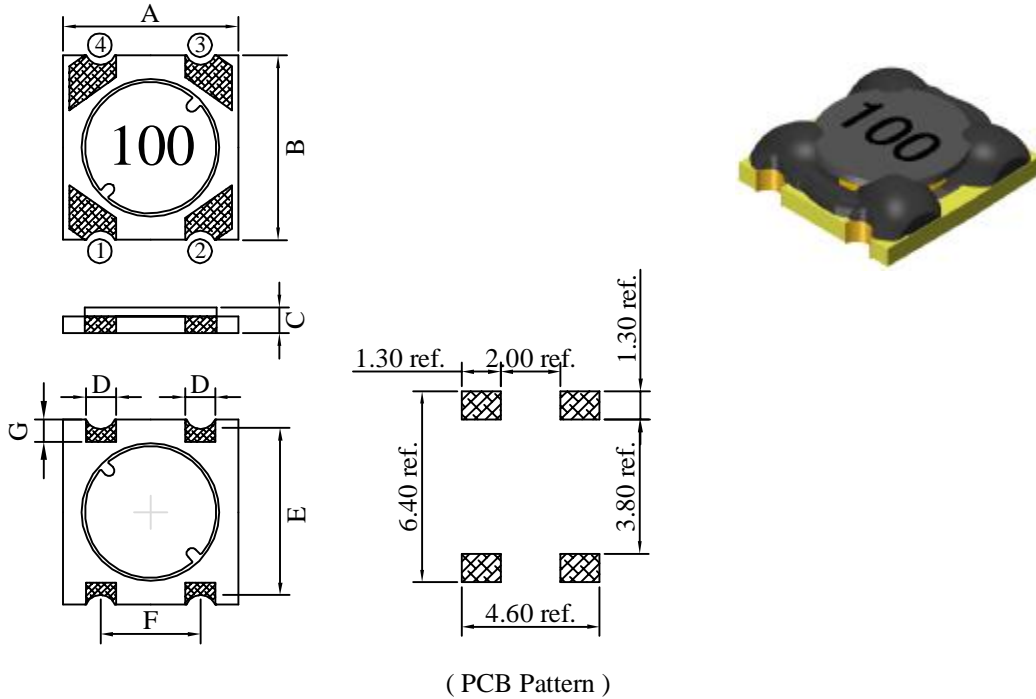

Unit : m/m

A	B	C	D	E	F	G
5.60±0.3	6.00±0.3	1.45±0.1	1.00 typ.	5.20 typ.	3.20 typ.	0.80 ref.

II . Schematic diagram :

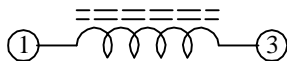

III . Description :

- a . Ferrite drum core construction.
- b . Enamelled copper wire : F class
- c . Product weight : 0.135g (ref.)
- d . Moisture sensitivity Level 1
- e . Products comply with RoHS' requirements
- f . Halogen free available.

Peak Temp : 260°C max.
 Max. Peak Temp - 5°C : 30sec max.
 Max time above 217°C : 60sec~150sec max.

IV . General specification :

- a . Storage temp. : -40°C ----+125°C
- b . Operating temp. : -40°C ----+125°C
(Temp. rise included)
- c . Resistance to solder heat : 260°C .10 secs.

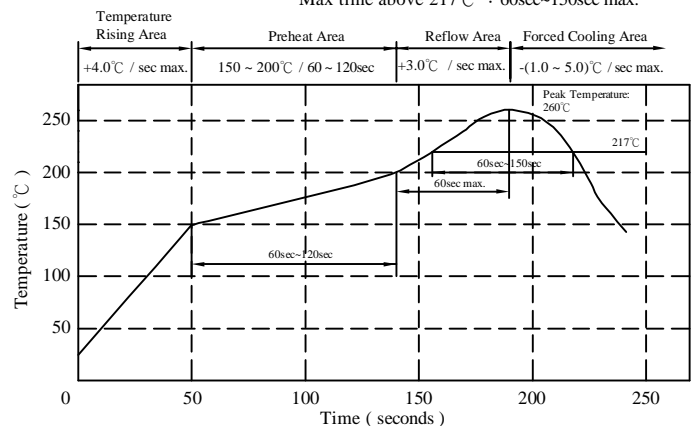

AR-001C

SPECIFICATION FOR APPROVAL

REF. :

PROD. NAME	SMD Power Inductor	ABC'S DWG NO.	SB5014□□□□L□-□□□		
		REV.	20130208-A	PAGE	2

V . Electrical characteristics :

DWG No.	Inductance (μH)	Test Freq. (Hz)	RDC (Ω) max.	I _{rms} (A) typ.	I _{sat} (A) typ.
SB50141R0ML□-□□□	1.0±20%	100K	0.032	2.50	2.80
SB50142R2ML□-□□□	2.2±20%	100K	0.058	1.80	2.10
SB50143R3ML□-□□□	3.3±20%	100K	0.078	1.60	1.72
SB50144R7ML□-□□□	4.7±20%	100K	0.105	1.20	1.40
SB50146R8ML□-□□□	6.8±20%	100K	0.150	1.05	1.15
SB5014100ML□-□□□	10.0±20%	100K	0.185	0.90	1.00
SB5014150ML□-□□□	15.0±20%	100K	0.300	0.65	0.80
SB5014220ML□-□□□	22.0±20%	100K	0.430	0.60	0.66
SB5014330ML□-□□□	33.0±20%	100K	0.625	0.45	0.53
SB5014470ML□-□□□	47.0±20%	100K	0.890	0.35	0.46
SB5014680ML□-□□□	68.0±20%	100K	1.250	0.30	0.35
SB5014101ML□-□□□	100.0±20%	100K	1.950	0.22	0.28

- | | |
|--|---|
| 1). □ : Packaging information : □ Code | 4). Inductance test freq. : 100KHz / 1V |
| 2). "- □□□" : Reference code | 5). I _{rms} base on temp. rise 40°C typ. |
| 3). Electrical specifications at 25°C | 6). I _{sat} base on ΔL/L0A=10 % typ. |

@ Inductance VS. DC Superposition Characteristics

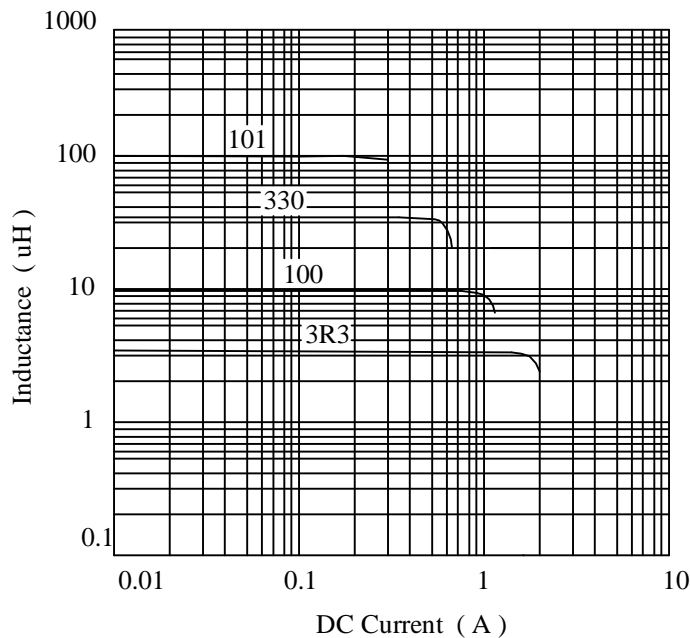

AR-001C

SPECIFICATION FOR APPROVAL

REF. :

PROD. NAME	SMD Power Inductor	ABC'S DWG NO.	SB5014□□□□L□-□□□		
		REV.	20130208-A	PAGE	3

VI . Packaging information :

(1) Configuration

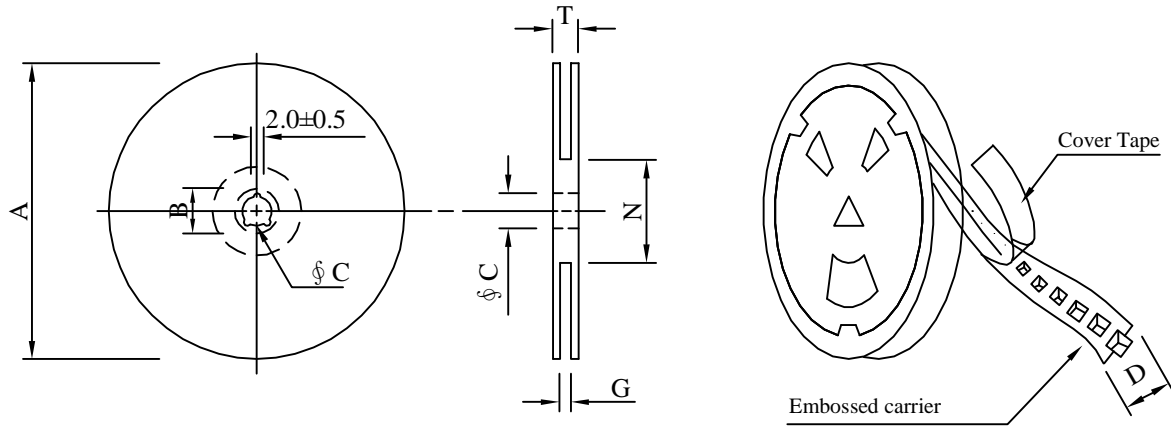

※Carrier Tape width : D

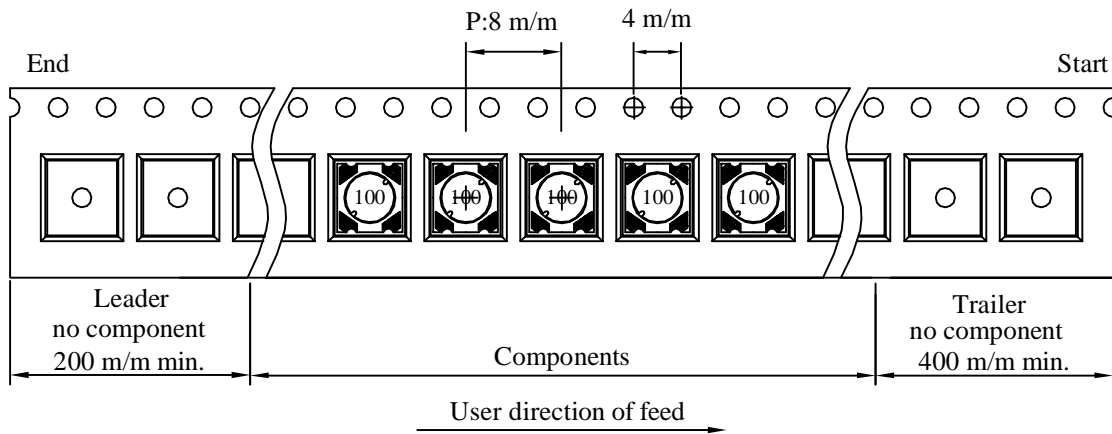

(2) Dimensions

Unit:m/m

Style	A	B	C	D	G	N	T
07-12	178	21±0.8	13	12	14 ⁺⁰	50 ⁻⁰	16.5

(3) Q'TY & G.W. Per package

Code	Inner : Reel			Outer : Carton		
	Q'TY (pcs)	G.W. (gw)	Style	Q'TY (pcs)	G.W. (Kg)	Size (cm)
B	1,000	120	07-12	40,000	4.7	42 x 41 x 24

AR-001C

SPECIFICATION FOR APPROVAL

REF. :

PROD. NAME	SMD Power Inductor	ABC'S DWG NO.	SB5014□□□□L□-□□□		
		REV.	20130208-A	PAGE	4

VII . Reliability test :

Item	Reference documents	Test Condition	Test Specification
1.High Temperature Exposure	MIL-STD-202 Method 108	1.Temperature: 125℃ 2.Time:96 hours.	1.No mechanical and electrical damage. 2.Inductance shall not change more than ±10%.
2.Temperature Cycling	JESD22 Method JA-104	1.Temperature: -40℃ ~ 125℃ 2.Number of cycle:96 cycle 3.Dwell time:30 minutes	1.No mechanical and electrical damage. 2.Inductance shall not change more than ±10%.
3.Biased Humidity Test	MIL-STD-202 Method 103	1.Temperature: 85±5℃ 2.Time:96 Hours 3.Humidity: 85±5% RH.	1.No mechanical and electrical damage. 2.Inductance shall not change more than ±10%.
4.Operational Life	MIL-PRF-27	1.Temperature: 125℃ 2.Time:96 hours. 3.Apply rated current.	1.No mechanical and electrical damage. 2.Inductance shall not change more than ±10%.
5.Exeternal Visual	MIL-STD-883 Method 2009	Inspect product constructions, marking and workmanship.	1.No pollution on the surface of products. 2.Clear marking. 3.No crack.
6.Physical Dimensions	JESD22 Method JB-100	Verify physical dimensions to the applicable product detail specification.	Per product specification standard
7.Resistance to solvents	MIL-STD-202 Method 215	Immerse into solvent for 3±0.5 minutes & brush 10 times for their cycles.	1.No body change in apperance. 2.No marking blurred. 3.Inductance shall not change more than ±10%.
8.Vibration Test	MIL-STD-202 Method 204	1.Frequency and Amplitued : 10-2000-10 Hz, 1.5 mm. 2.Direction:X, Y, Z 3.Test duration:2 hours for each direction, 6 hours in total.	1.No mechanical and electrical damage. 2.Inductance shall not change more than ±10%.
9.Resistance To Soldering Heat Test	MIL-STD-202 Method 210	1.Highest temperature : 260±5℃ 2.Time (temp. ≥ 217℃) : 60~150 Second. 3.IR reflow times : 3 times.	1.No mechanical and electrical damage. 2.Inductance shall not change more than ±10%.
10.Rated current	MIL-STD-202 Method 330	Apply rated current for 5 second.	1.No mechanical and electrical damage. 2.Inductance shall not change more than ±10%.
11.Temperature rise	MIL-PRF-27	Apply rated current for 10 minutes.	1.No mechanical and electrical damage. 2.Inductance shall not change more than ±10%.
12.Over load	MIL-PRF-27	Apply twice as rated current for 5 minutes. (It's not application to some special design)	1.No mechanical and electrical damage. 2.Inductance shall not change more than ±10%.
13.Solderability Test	J-STD-002	1.Baking in pre-testing : 155±5℃ / 16Hours±30 min. 2.Peak temperature : 240±5℃ 3.Time (temp. ≥ 217℃) : 60~150 second. 4.IR reflow times : 1 times.	The terminal shall be at least 95% covered with fresh solder.
14.Electrical Characteriazation	User Spec.	1.Operating temperature : -40℃~125℃ 2.Room temperature : 25℃.	1.No mechanical and electrical damage. 2.Inductance shall not change more than ±10%.
15.Withstanding Voltage Test	MIL-STD-202 Method 201	1.DV:500V 2.Time:1minutes	1.During the test no breakdown. 2.The characteristic is normal after test.
16.Drop	JESD22-B111	Packaged & Drop down from 1m.In 1 angle 1ridges & 2 surfaces orientation.	1.No case deformation or change in appearance. 2.Inductance shall not change more than ±10%.
17.Terminal Strength Test	JIS-C-6429	1.Apply push force to samples mounted on PCB. 2.Force of 1.8 kg for 60±1 seconds.	After test, inductors shall be no mechanical damage.

AR-001C

