

# SPECIFICATION FOR APPROVAL

REF. :

PROD. NAME	SMD Line Filter	ABC'S DWG NO.	SF0904□□□□P□-□□□		
		REV.	20121008-C	PAGE	1

**I . Configuration and dimensions :**

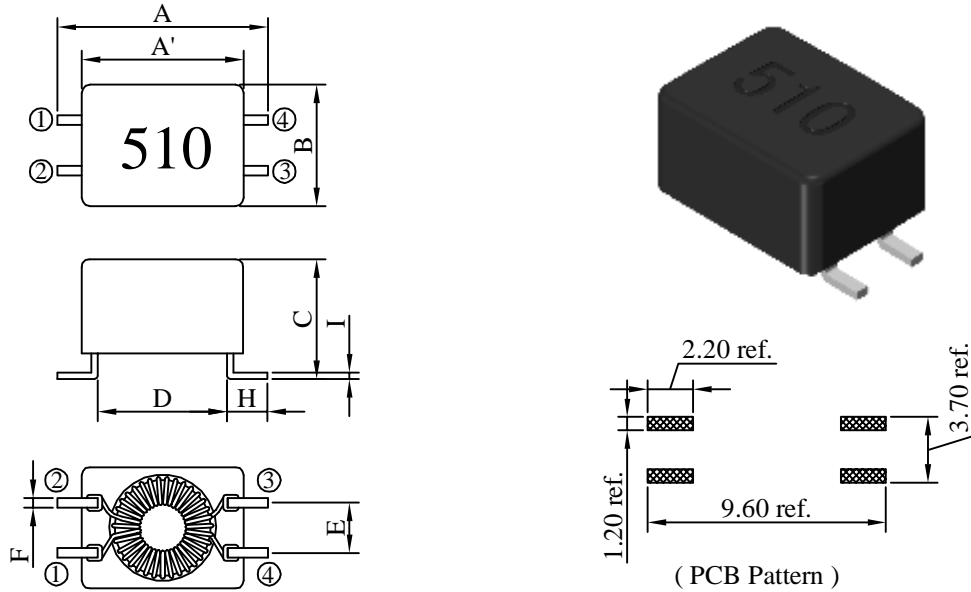

Unit : m/m

A	A'	B	C	D	E	F	H	I
9.00±0.3	7.30 typ.	5.40±0.2	4.70±0.15	5.50 typ.	2.54 typ.	0.50 typ.	1.75 typ.	0.30 typ.

**II . Schematic diagram :**

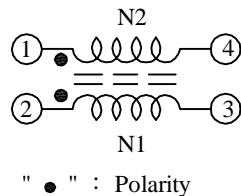

**III . Description :**

- a . Ferrite toroidal core construction.
- b . Enamelled copper wire : H class
- c . Product weight : 0.27g (ref.)
- d . Moisture sensitivity Level 1
- e . Products comply with RoHS' requirements
- f . Halogen free available

**IV . General specification :**

- a . Storage temp. : -40°C ---- +105°C
- b . Operating temp. : -40°C ---- +105°C  
(Temp. rise included)
- c . Resistance to solder heat : 250°C . 10 secs.

Peak Temp : 250°C max.  
Max. Peak Temp - 5°C : 30sec max.  
Max time above 217°C : 60sec~150sec max.

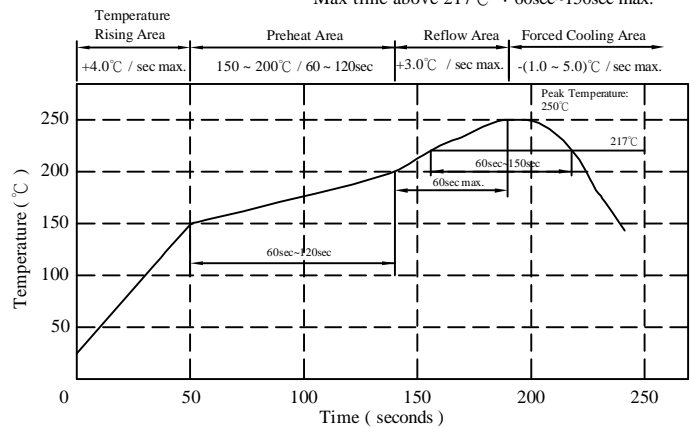

AR-001C

# SPECIFICATION FOR APPROVAL

REF. :

PROD. NAME	SMD Line Filter	ABC'S DWG NO.	SF0904□□□□P□-□□□		
		REV.	20121008-C	PAGE	2

V . Electrical characteristics :

DWG No.	L (1-4) @ 100KHz,0.1 Vrms ( μH )	LL (1-4) ( μH ) @ 100KHz,0.1 Vrms typ. ( 2-3 short )	RDC ( Ω ) max.	Rated Current max. (A)	Impedance ( Ω ) min.	Freq. Range ( MHz )	Winding
SF0904110YP□-□□□	11.0±25%	0.05	0.12	0.5	300	20~300	Bifilar
SF0904250YP□-□□□	25.0±25%	1.50	0.20	0.5	700	20~150	Sector
SF0904510YP□-□□□	51.0±25%	2.00	0.30	0.5	1500	20~100	Sector
SF0904101YP□-□□□	100.0±25%	0.85	0.10	0.5	700	3~20	Sector
SF0904471YP□-□□□	470.0±25%	0.28	0.28	0.5	2000	2~15	Bifilar
SF0904102YP□-□□□	1000.0±25%	0.29	0.40	0.5	2800	1~10	Bifilar
SF0904472YP□-□□□	4700.0±25%	0.30	0.70	0.2	6000	0.5~3	Bifilar

- 1). □: Packaging information : □ Code
- 2). "- □□□" : Reference code
- 3). Electrical specifications at 25°C
- 4). Rated voltage 80 Vdc / 42 Vac
- 5). Hi-Pot ( N-N ) : 250 Vac / 60 Hz , 3 mA / 1sec.
- 6). Rated current base on Temp. rise 30°C max.

AR-001C

# SPECIFICATION FOR APPROVAL

REF. :

PROD. NAME	SMD Line Filter	ABC'S DWG NO.	SF0904□□□□P□-□□□		
		REV.	20121008-C	PAGE	3

VI . Curve :

Impedance VS. Frequency

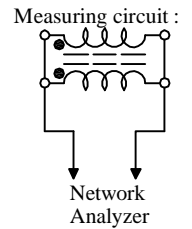
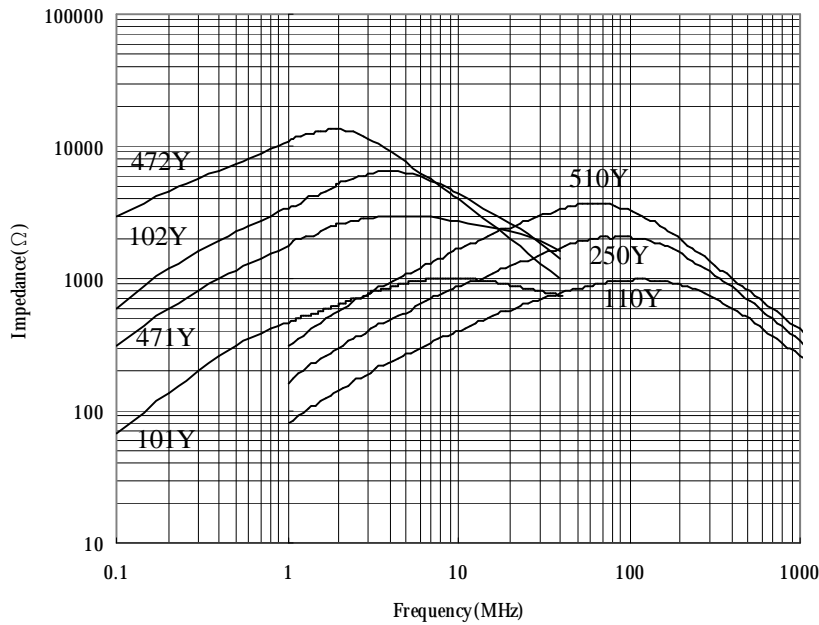

Impedance VS. Frequency

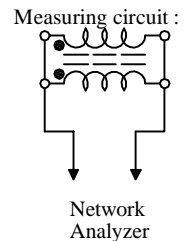
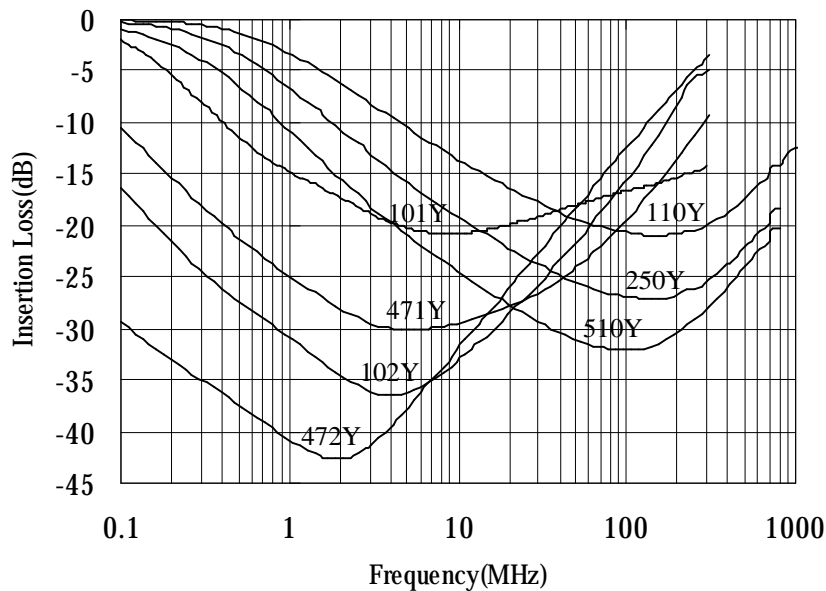

AR-001C

# SPECIFICATION FOR APPROVAL

REF. :

PROD. NAME	SMD Line Filter	ABC'S DWG NO.	SF0904□□□□P□-□□□		
		REV.	20121008-C	PAGE	4

## VII . Packaging information :

### (1) Configuration

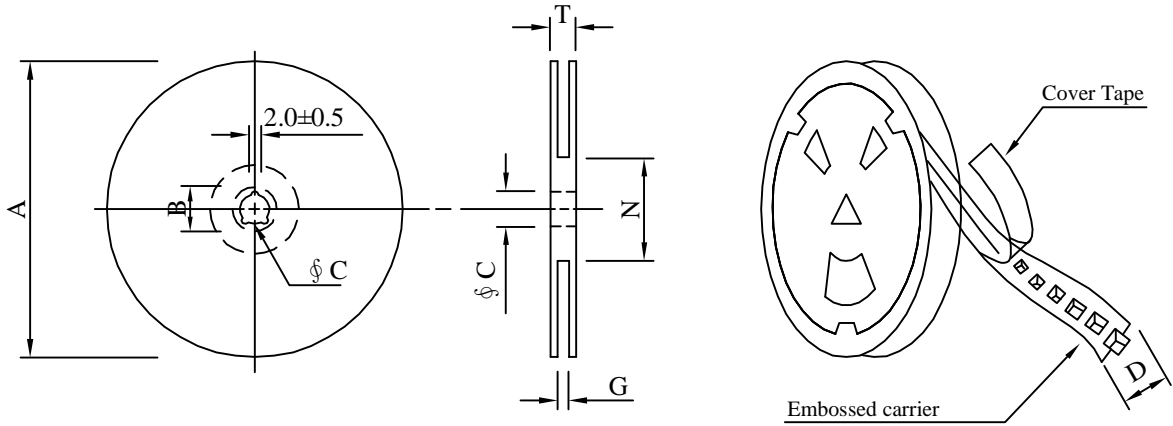

※Carrier tape width : D

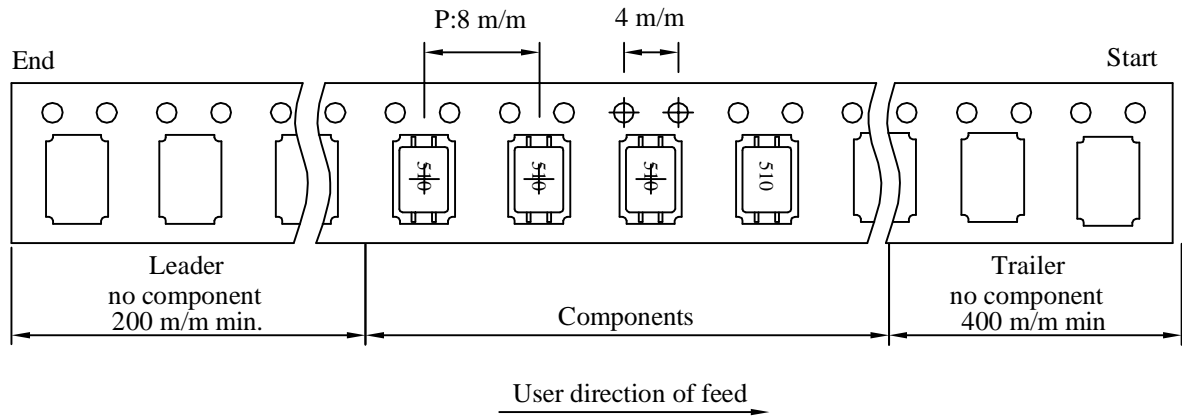

### (2) Dimensions

Unit:m/m

Style	A	B	C	D	G	N	T
13 - 16	330	21±0.8	13±0.5	16	18 <sup>+0</sup>	50 <sup>-0</sup>	22.4

### (3) Q'TY & G.W. Per package

Code	Inner : Reel			Outer : Carton		
	Q'TY (pcs)	G.W. (gw)	Style	Q'TY (pcs)	G.W. (Kg)	Size (cm)
B	1,500	600	13 - 16	9,000	8.0	38 x 37 x 22

AR-001C

# SPECIFICATION FOR APPROVAL

REF. :

PROD. NAME	SMD Line Filter	ABC'S DWG NO.	SF0904□□□□P□-□□□		
		REV.	20121008-C	PAGE	5

### VIII . Reliability test :

Item	Reference documents	Test Condition	Test Specification
1.High Temperature Exposure	MIL-STD-202 Method 108	1.Temperature: 105°C 2.Time:96 hours.	1.No mechanical and electrical damage. 2.Inductance shall not change more than ±50%.
2.Temperature Cycling	JESD22 Method JA-104	1.Temperature: -40°C ~ 105°C 2.Number of cycle:96 cycle 3.Dwell time:30 minutes	1.No mechanical and electrical damage. 2.Inductance shall not change more than ±50%.
3.Biased Humidity Test	MIL-STD-202 Method 103	1.Temperature: 85±5 °C 2.Time:96 Hours 3.Humidity: 85±5% RH.	1.No mechanical and electrical damage. 2.Inductance shall not change more than ±50%.
4.Operational Life	MIL-PRF-27	1.Temperature: 105°C 2.Time:96 hours. 3.Apply rated current.	1.No mechanical and electrical damage. 2.Inductance shall not change more than ±50%.
5.Exeternal Visual	MIL-STD-883 Method 2009	Inspect product constructions, marking and workmanship.	1.No pollution on the surface of products. 2.Clear marking. 3.No crack.
6.Physical Dimensions	JESD22 Method JB-100	Verify physical dimensions to the applicable product detail specification.	Per product specification standard
7.Resistance to solvents	MIL-STD-202 Method 215	Immerse into solvent for 3±0.5 minutes & brush 10 times for their cycles.	1.No body change in apperarence. 2.No marking blurred. 3.Inductance shall not change more than ±50%.
8.Vibration Test	MIL-STD-202 Method 204	1.Frequency and Amplitued : 10-2000-10 Hz, 1.5 mm. 2.Direction:X, Y, Z 3.Test duration:2 hours for each direction, 6 hours in total.	1.No mechanical and electrical damage. 2.Inductance shall not change more than ±50%.
9.Resistance To Soldering Heat Test	MIL-STD-202 Method 210	1.Highest temperature : 250±5°C 2.Time ( temp.≥ 217°C ) : 60~150 Second. 3.IR reflow times : 3 times.	1.No mechanical and electrical damage. 2.Inductance shall not change more than ±50%.
10.Rated current	MIL-STD-202 Method 330	Apply rated current for 5 second.	1.No mechanical and electrical damage. 2.Inductance shall not change more than ±50%.
11.Temperature rise	MIL-PRF-27	Apply rated current for 10 minutes.	1.No mechanical and electrical damage. 2.Inductance shall not change more than ±50%.
12.Over load	MIL-PRF-27	Apply twice as rated current for 5 minutes. (It's not application to some special design)	1.No mechanical and electrical damage. 2.Inductance shall not change more than ±50%.
13.Solderability Test	J-STD-002	1.Baking in pre-testing : 155±5°C / 16Hours±30 min. 2.Peak temperature : 240±5°C 3.Time ( temp.≥ 217°C ) : 60~150 second. 4.IR reflow times : 1 times.	The terminal shall be at least 95% covered with fresh solder.
14.Electrical Characteriazation	User Spec.	1.Operating temperature : -40°C~105°C 2.Room temperature : 25°C.	1.No mechanical and electrical damage. 2.Inductance shall not change more than ±50%.
15.Withstanding Voltage Test	MIL-STD-202 Method 201	1.DV:500V 2.Time:1minutes	1.During the test no breakdown. 2.The characteristic is normal after test.
16.Drop	JESD22-B111	Packaged & Drop down from 1m.In 1 angle Iridges & 2 surfaces orientation.	1.No case deformation or change in appearance. 2.Inductance shall not change more than ±50%.
17.Terminal Strength Test	JIS-C-6429	1.Apply push force to samples mounted on PCB. 2.Force of 1.8 kg for 60±1 seconds.	After test, inductors shall be no mechanical damage.

AR-001C