

SPECIFICATION FOR APPROVAL

REF. :

PROD. NAME	Shielded SMD Power Inductor	ABC'S DWG NO.	SS1258□□□□L□-□□□		
		REV.	20160901-F	PAGE	1

I . Configuration and dimensions :

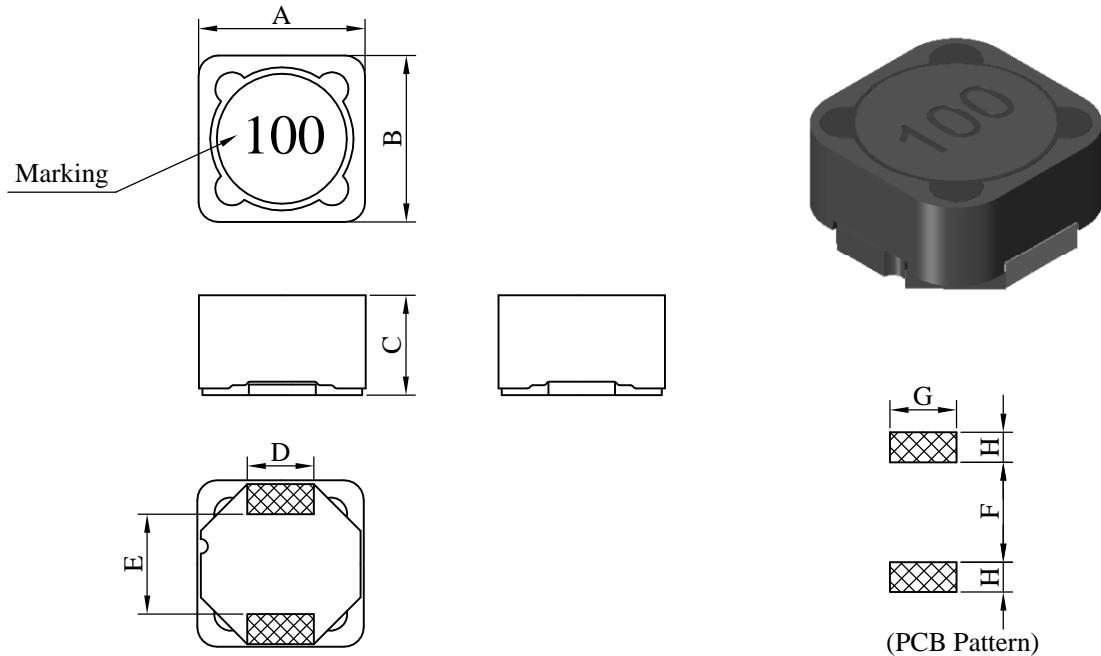

Unit : m/m

A	B	C	D	E	F	G	H
12.00 ±0.3	12.00 ±0.3	6.00±0.2	5.00 typ.	5.70 typ.	4.50 ref.	5.50 ref.	4.00 ref.

II . Description :

- a . Ferrite drum core construction.
- b . Magnetically shielded.
- c . Enamelled copper wire : F & H class
- d . Product weight : 3.10g (ref.)
- e . Moisture sensitivity Level 1
- f . Products comply with RoHS' requirements
- g . Halogen free available

III . General specification :

- a . Storage temp. : -40°C ----+125°C
- b . Operating temp. : -40°C ----+125°C
(Temp. rise included)
- c . Resistance to solder heat : 245°C.10 secs.

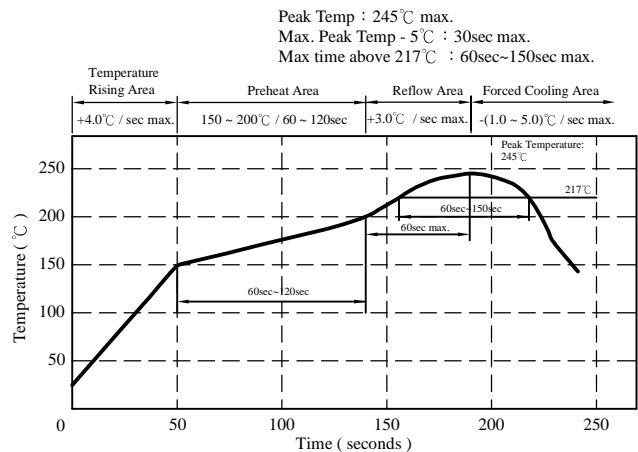

AR-001C

SPECIFICATION FOR APPROVAL

REF. :

PROD. NAME	Shielded SMD Power Inductor	ABC'S DWG NO.	SS1258□□□□L□-□□□		
		REV.	20160901-F	PAGE	2

IV . Electrical characteristics :

DWG No.	Inductance (μH)	Q ref.	Test Freq. (MHZ)	SRF (MHz) typ.	RDC (mΩ) max.	Irms (A)	Isat (A)
SS12581R0YL□-□□□	1.0±35%	26	7.96	100.00	10	8.00	15.00
SS12581R8YL□-□□□	1.8±35%	24	7.96	80.00	13	7.50	14.00
SS12582R2YL□-□□□	2.2±35%	22	7.96	55.00	14	7.00	11.40
SS12583R3YL□-□□□	3.3±35%	20	7.96	42.00	16	7.00	9.70
SS12584R7YL□-□□□	4.7±35%	19	7.96	33.00	20	7.00	8.00
SS12585R6YL□-□□□	5.6±35%	19	7.96	30.00	22	6.40	7.50
SS12586R8YL□-□□□	6.8±35%	20	7.96	27.00	23	5.90	6.70
SS12588R2YL□-□□□	8.2±35%	18	7.96	26.00	25	4.80	6.00
SS1258100ML□-□□□	10.0±20%	32	2.52	22.00	28	4.00	5.50
SS1258120ML□-□□□	12.0±20%	27	2.52	20.00	32	3.70	5.10
SS1258150ML□-□□□	15.0±20%	25	2.52	18.00	40	3.50	4.60
SS1258180ML□-□□□	18.0±20%	28	2.52	16.00	45	3.30	4.10
SS1258220ML□-□□□	22.0±20%	29	2.52	15.00	52	3.10	3.70
SS1258270ML□-□□□	27.0±20%	26	2.52	13.00	65	2.90	3.20
SS1258330ML□-□□□	33.0±20%	27	2.52	12.40	75	2.70	3.00
SS1258390ML□-□□□	39.0±20%	22	2.52	12.00	80	2.60	2.80
SS1258470ML□-□□□	47.0±20%	22	2.52	11.60	100	2.50	2.60
SS1258560ML□-□□□	56.0±20%	24	2.52	10.50	120	2.40	2.50
SS1258680ML□-□□□	68.0±20%	22	2.52	10.00	130	2.30	2.30
SS1258820ML□-□□□	82.0±20%	25	2.52	8.60	160	2.20	2.00
SS1258101ML□-□□□	100.0±20%	26	0.796	7.80	190	2.10	1.80
SS1258121KL□-□□□	120.0±10%	26	0.796	6.80	250	1.85	1.65
SS1258151KL□-□□□	150.0±10%	20	0.796	6.40	280	1.66	1.55
SS1258181KL□-□□□	180.0±10%	26	0.796	6.10	320	1.58	1.30
SS1258221KL□-□□□	220.0±10%	22	0.796	5.50	420	1.35	1.20
SS1258271KL□-□□□	270.0±10%	20	0.796	4.30	480	1.30	1.10
SS1258331KL□-□□□	330.0±10%	22	0.796	4.00	630	1.16	1.00
SS1258391KL□-□□□	390.0±10%	20	0.796	3.60	700	1.08	0.95
SS1258471KL□-□□□	470.0±10%	18	0.796	3.00	900	0.96	0.85
SS1258561KL□-□□□	560.0±10%	22	0.796	2.80	1000	0.88	0.80
SS1258681KL□-□□□	680.0±10%	18	0.796	2.60	1200	0.80	0.75
SS1258821KL□-□□□	820.0±10%	20	0.796	2.50	1600	0.73	0.68
SS1258102KL□-□□□	1000.0±10%	30	0.252	2.40	1850	0.68	0.60

- 1). □ : Packaging information : □ Code
- 2). "-□□□" : Reference code
- 3). Electrical specifications at 25°C
- 4). Inductance Test Freq. : 1kHz / 0.1V
- 5). Irms base on Temp. rise 40°C typ.
- 6). Isat base on ΔL/LOA=20% max.

AR-001C

SPECIFICATION FOR APPROVAL

REF. :

PROD. NAME	Shielded SMD Power Inductor	ABC'S DWG NO.	SS1258□□□□L□-□□□		
		REV.	20160901-F	PAGE	3

V . Curve :

SS12584R7YL□

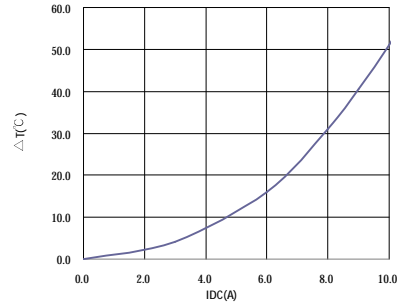
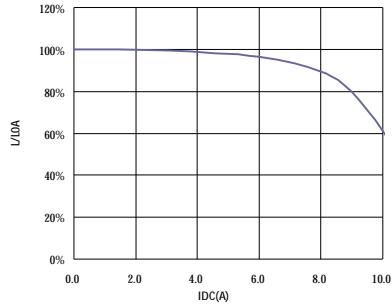

SS1258220ML□

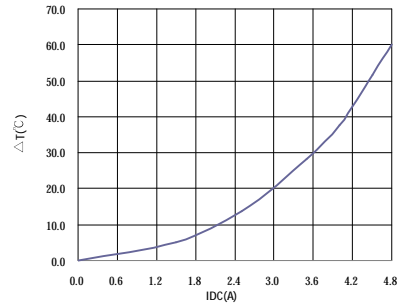
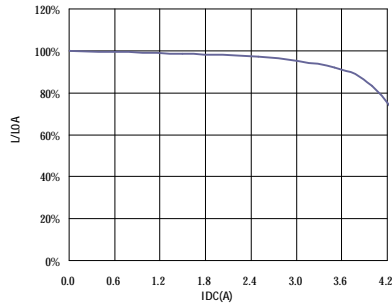

SS1258681KL□

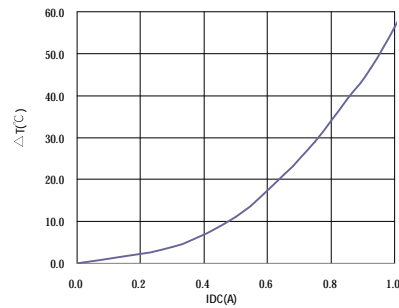
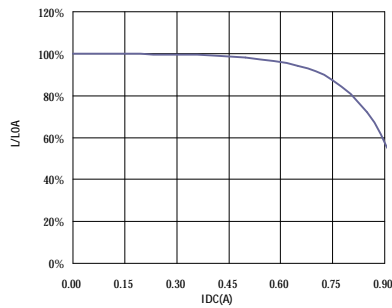

SS1258102KL□

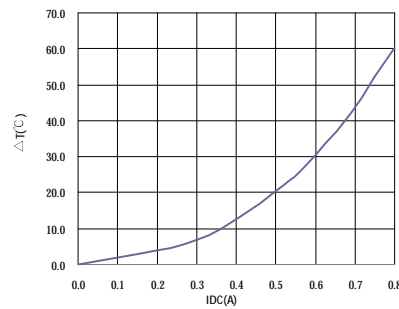
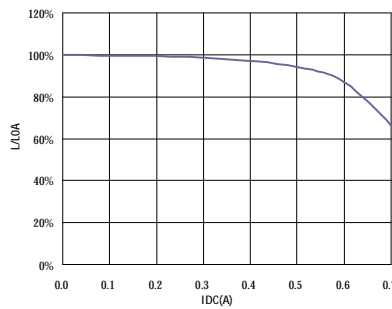

AR-001C

SPECIFICATION FOR APPROVAL

REF. :

PROD. NAME	Shielded SMD Power Inductor	ABC'S DWG NO.	SS1258□□□□L□-□□□		
		REV.	20160901-F	PAGE	4

VI . Packaging information :

(1) Configuration

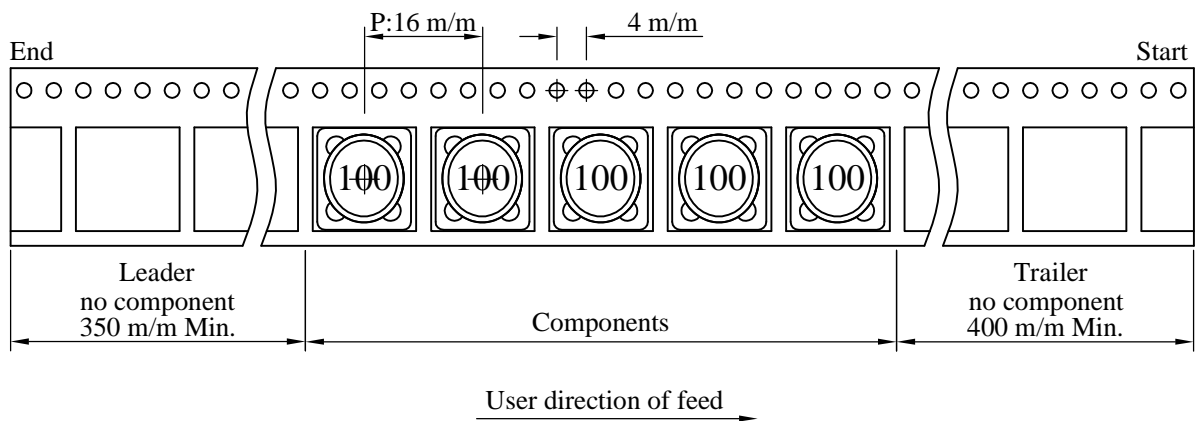
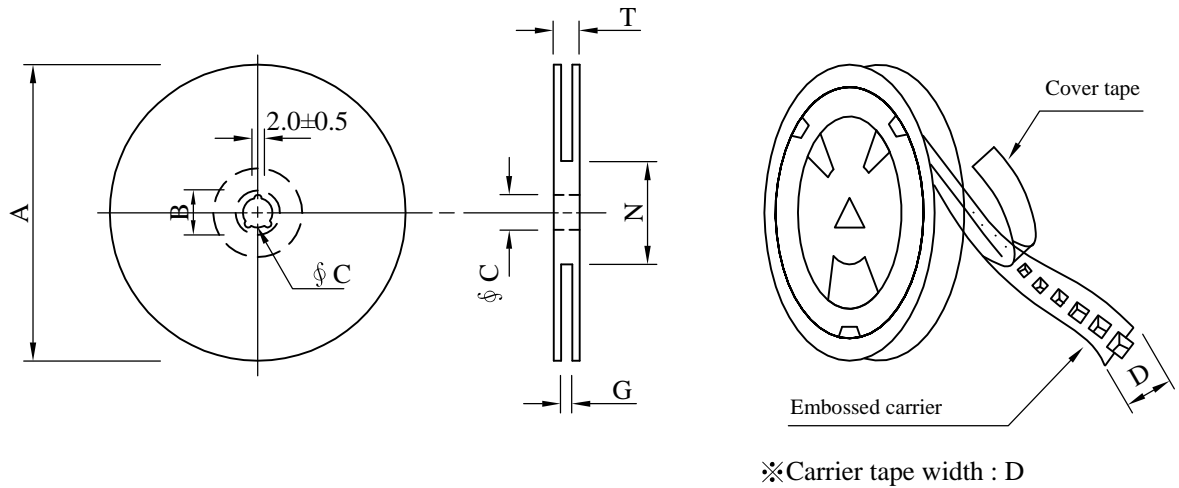

(2) Dimensions

Unit:m/m

Style	A	B	C	D	G	N	T
13 - 24	330	21±0.8	13±0.5	24	26 ⁺⁰	60 ⁻⁰	30.4

(3) Q'TY & G.W. Per package

Code	Inner : Reel			Outer : Carton		
	Q'TY (pcs)	G.W. (gw)	Style	Q'TY (pcs)	G.W. (Kg)	Size (cm)
B	600	2290	13 - 24	2,400	10.5	38 x 37 x 22

AR-001C

SPECIFICATION FOR APPROVAL

REF. :

PROD. NAME	Shielded SMD Power Inductor	ABC'S DWG NO.	SS1258□□□□L□-□□□		
		REV.	20160901-F	PAGE	5

VI . Drawing number expression :

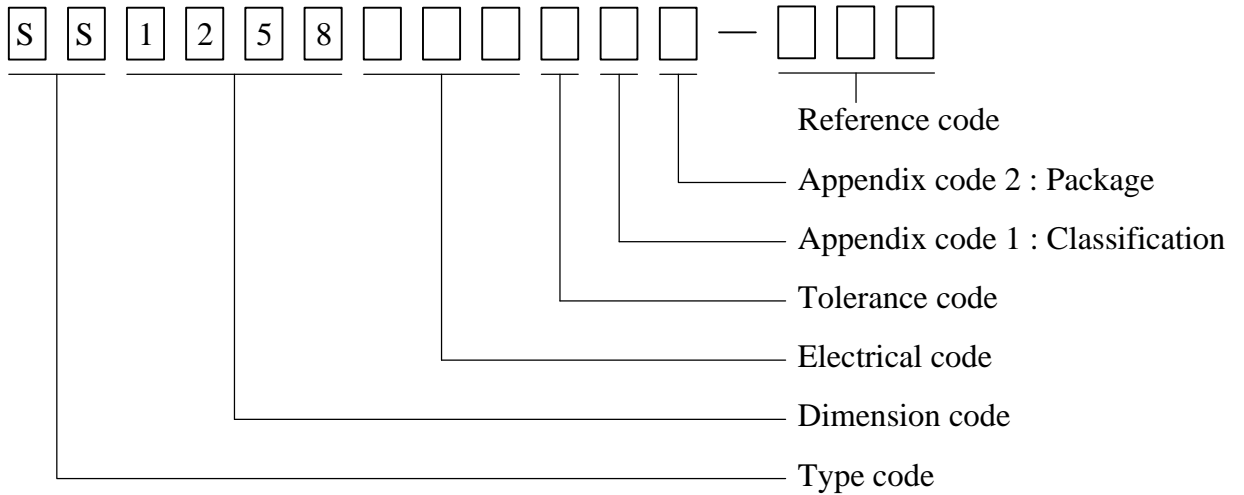

Appendix code 1 : Product Classification

Appendix code 2 : Package Information

Code	Inner package	Cover tape	Carrier tape	Bag	Package Q'TY	Remark
B	T/R (Reel package)	UCT	Antistatic	Antistatic	600 pcs	

AR-001C

SPECIFICATION FOR APPROVAL

REF. :

PROD. NAME	Shielded SMD Power Inductor	ABC'S DWG NO.	SS1258□□□□L□-□□□		
		REV.	20160901-F	PAGE	6

VII . Reliability test :

Item	Reference documents	Test Condition	Test Specification
1.High Temperature Exposure	MIL-STD-202 Method 108	1.Temperature: 125±2℃ 2.Time:96±2 hours.	1.No mechanical or electrical damage. 2.Inductance shall not change more than ±20%.
2.Temperature Cycling	JESD22-A 104	1.Temperature: -40℃ ~ +125℃ 2.Number of cycle:100 cycle 3.Dwell time:30 minutes	1.No mechanical or electrical damage. 2.Inductance shall not change more than ±20%.
3.Biased Humidity Test	MIL-STD-202 Method 103	1.Temperature : 85±2℃ 2.Humidity: 85% RH. 3.Time:96±2 Hours	1.No mechanical or electrical damage. 2.Inductance shall not change more than ±20%.
4.Operational Life	JESD22-A 108	1.Temperature: 125℃ (Temp. rise included) 2.Time:96±2 hours. 3.Rated current	1.No mechanical or electrical damage. 2.Inductance shall not change more than ±20%.
5.External Visual	JESD22-B 101 & MIL-STD-883 Method 2009	Inspect product constructions, marking and workmanship.	1.No pollution on the surface of products. 2.Clear marking. 3.No crack.
6.Physical Dimensions	JESD22-B 100	Verify physical dimensions to the applicable product detail specification.	Per product specification standard
7.Resistance to solvents	MIL-STD-202 Method 215	Immerse into solvent for 3±0.5 minutes & brush 10 times for 3 cycles.	1.No body change in appearance. 2.No marking blurred. 3.Inductance shall not change more than ±20%.
8.Vibration Test	MIL-STD-202 Method 204	1.Frequency and Amplitud : 10-2000-10 Hz, 1.5 mm. 2.Direction:X, Y, Z 3.Test duration:2 hours for each direction, 6 hours in total.	1.No mechanical or electrical damage. 2.Inductance shall not change more than ±20%.
9.Resistance To Soldering Heat Test	MIL-STD-202 Method 210 & J-STD020D.1	1.Highest temperature : 245±5℃ 2.Time (temp. ≥ 217℃) : 60~150 Second. 3.IR reflow times : 3 times.	1.No mechanical or electrical damage. 2.Inductance shall not change more than ±20%.
10.Saturation Current	JIS C 6436 & User SPEC.	1.Applied rated current for 5 second. 2.Saturation current	Inductance shall not drop more than 20% max.
11.Over load	JIS C 6436 & User SPEC.	1.Applied one and half rated current for a period of 5 minutes. 2.Rated current	No electrical or mechanical damage
12.Temperature Rise Current	JIS C 6436 & User SPEC.	1.Applied rated current for 10 minutes. 2.Temperature measure by digital surface thermometer. 3.Irms current	Surface temperature rise is less than 40℃ typ.
13.Solderability Test	J-STD-002 & JESD22-B 102	1.Baking in pre-testing : 150±5℃ / 16Hours±30 min. 2.Peak temperature : 240±5℃ 3.Time (temp. ≥ 217℃) : 60~150 second. 4.IR reflow times : 1 times.	More than 95% soldering coverage min on terminations.
14.Electrical Characteriazation	MIL-STD-202 Method 304 & User SPEC.	1.Operating temperature : -40℃~125℃ 2.Room temperature : 25℃.	1.No mechanical or electrical damage. 2.Inductance shall not change more than ±20%.
15.Drop	CNS-C6354 & GB/T 2423.8	1.Products shall be mounted on SPEC. PCB and dropped down from a height of 1m 2.Drop total time : 6 time (Every side of sample drop 2 time)	1. Adhesion on PCB shall be enough. 2. Product appearance shall not break. 3. No electrical damage.
16.Terminal Strength Test	IEC 60068-2-21	1.Apply push force to samples mounted on PCB. 2.Force of 1.8 kg for 60±1 seconds.	After test, inductors shall be no mechanical damage.

AR-001C