

SPECIFICATION FOR APPROVAL

REF. :

PROD. NAME	SMD Toroidal Power Filter	ABC'S DWG NO.	ST1510□□□□L□-□□□		
		REV.	20160427-C	PAGE	1

I . Configuration and dimensions :

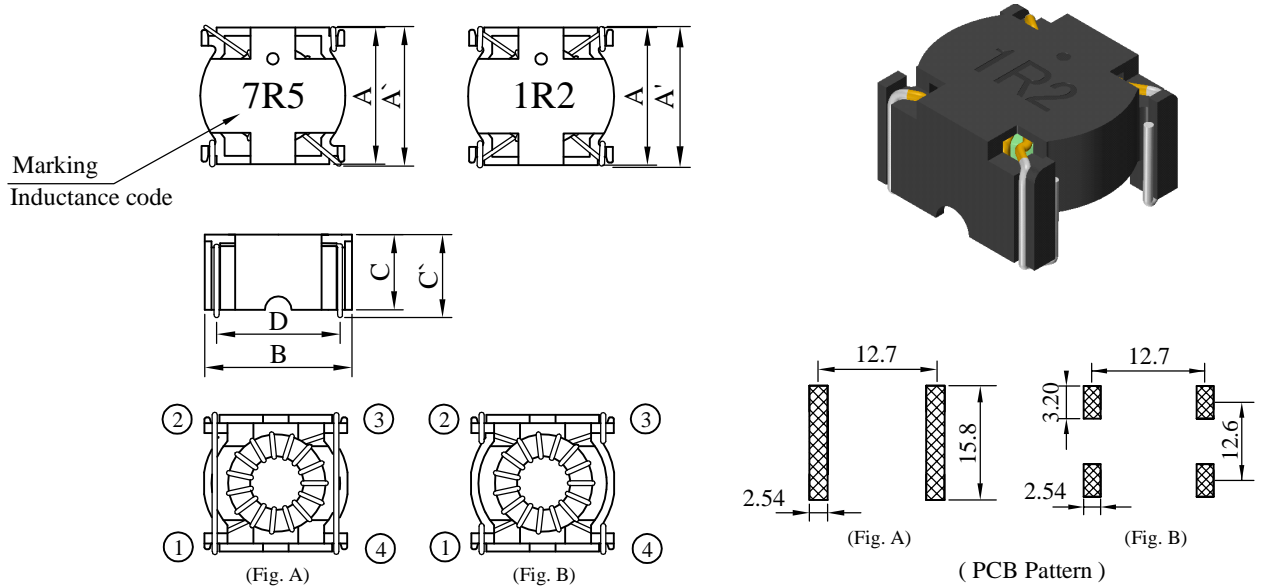

Unit : m/m

A	A'	B	C	C'	D
14.60 ±0.30	15.80 max.	15.50 ±0.30	8.89 typ.	10.50 max.	12.70 typ.

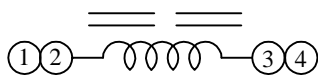

(Fig. A)

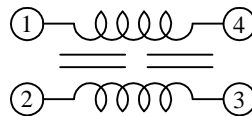

(Fig. B)

II . Description :

- a . Iron toroidal core construction.
- b . Enamelled copper wire : F class
- c . Product weight : 3.30 g (ref.)
- d . Moisture sensitivity Level 1
- e . Products comply with RoHS' requirements
- f . Halogen free available

III . General specification :

- a . Storage Temp. : -40°C ----+125°C
- b . Operating Temp. : -40°C ----+125°C
(Temp. rise included)
- c . Resistance to solder heat : 245°C .10 Secs.

Peak Temp : 245°C max.
Max. Peak Temp - 5°C : 30sec max.
Max time above 217°C : 60sec~150sec max.

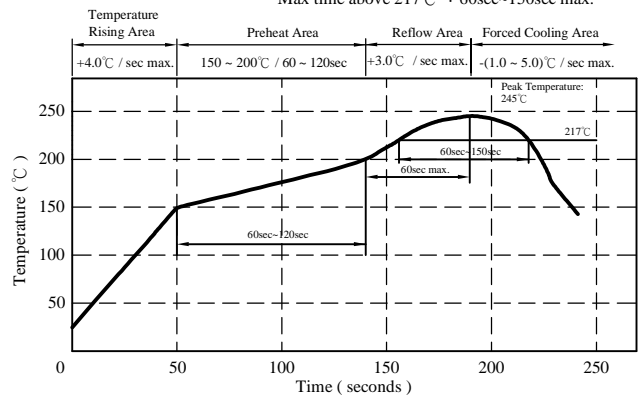

AR-001C

SPECIFICATION FOR APPROVAL

REF. :

PROD. NAME	SMD Toroidal Power Filter	ABC'S DWG NO.	ST1510□□□□L□-□□□		
		REV.	20160427-C	PAGE	2

IV . Electrical characteristics :

DWG No.	Inductance @ 10kHz, 0.1 Vrms (μH)	RDC(mΩ) (Each Winding)		Irms (A) typ.	Isat (A) typ.	Fig.
		max.	typ.			
ST15101R2ML□-□□□	1.2 ± 20%	10.0	7.8	10.0	12.5	B
ST15102R3ML□-□□□	2.3 ± 20%	13.5	10.3	9.5	9.0	B
ST15107R5ML□-□□□	7.5 ± 20%	13.5	10.1	7.8	5.5	A
ST1510140ML□-□□□	14.0 ± 20%	24.0	19.2	5.4	3.4	A
ST1510430ML□-□□□	43.0 ± 20%	56.0	44.7	3.5	1.9	A
ST1510500ML□-□□□	50.0 ± 20%	60.0	47.0	3.3	1.75	A

- 1). □ : Packaging information : □ Code
- 2). "-□□□" : Reference code
- 3). Electrical specifications at 25°C
- 4). Irms base on Temp. rise 40°C typ.
- 5). Isat base on ΔL/L0A=30% typ.

@ Inductance VS. DC Superposition Characteristics

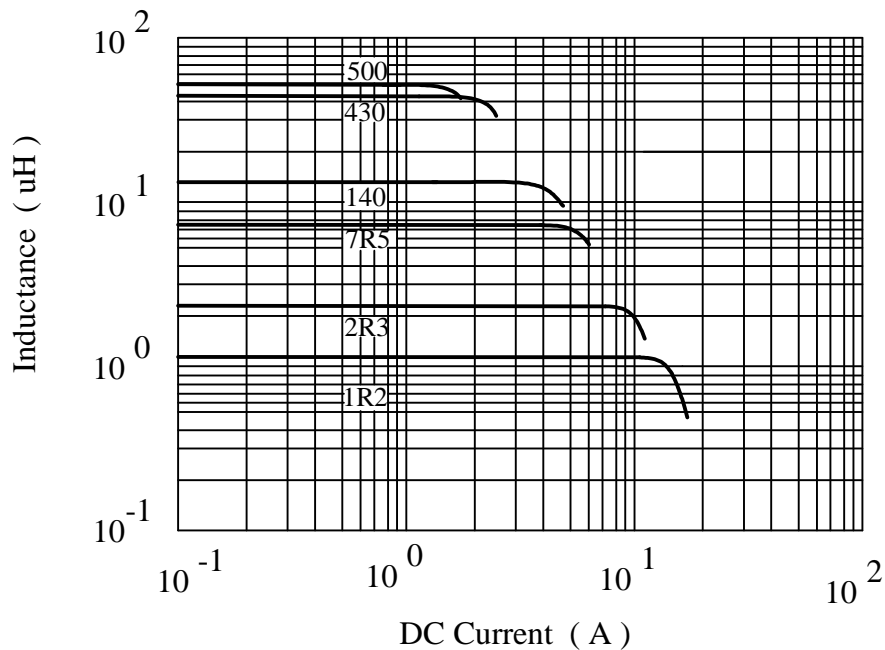

AR-001C

SPECIFICATION FOR APPROVAL

REF. :

PROD. NAME	SMD Toroidal Power Filter	ABC'S DWG NO.	ST1510□□□□L□-□□□		
		REV.	20160427-C	PAGE	3

@ DC Current VS Temperature Rise

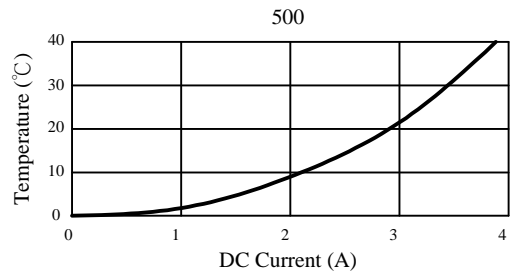
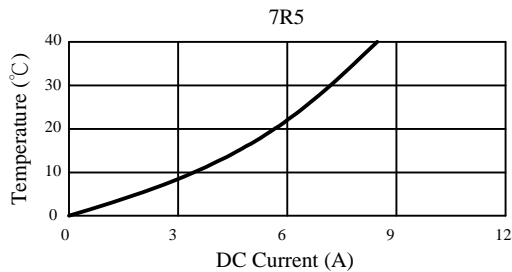
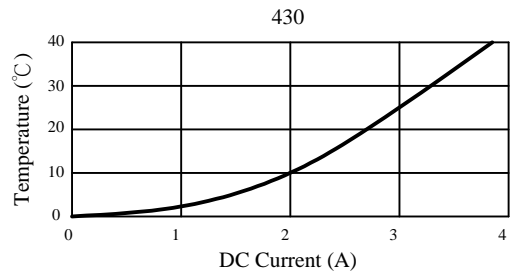
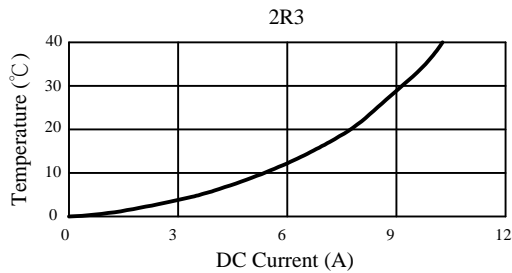
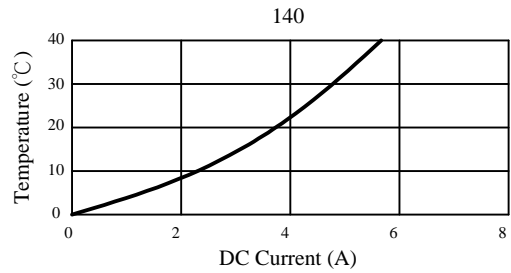
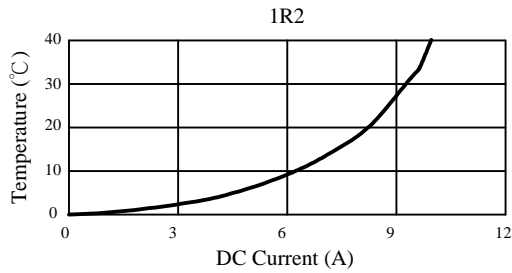

AR-001C

SPECIFICATION FOR APPROVAL

REF. :

PROD. NAME	SMD Toroidal Power Filter	ABC'S DWG NO.	ST1510□□□□L□-□□□		
		REV.	20160427-C	PAGE	4

V . Packaging information :

(1) Configuration

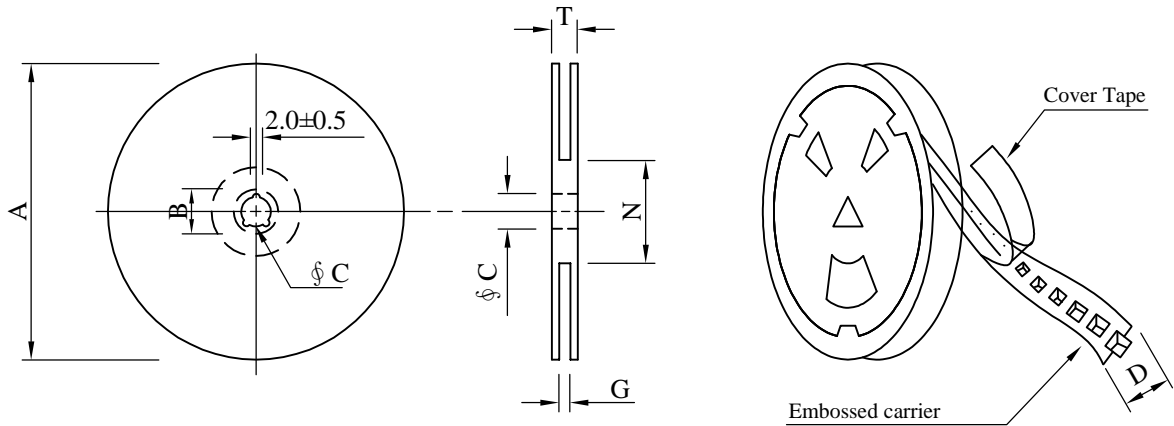

※Carrier tape width : D

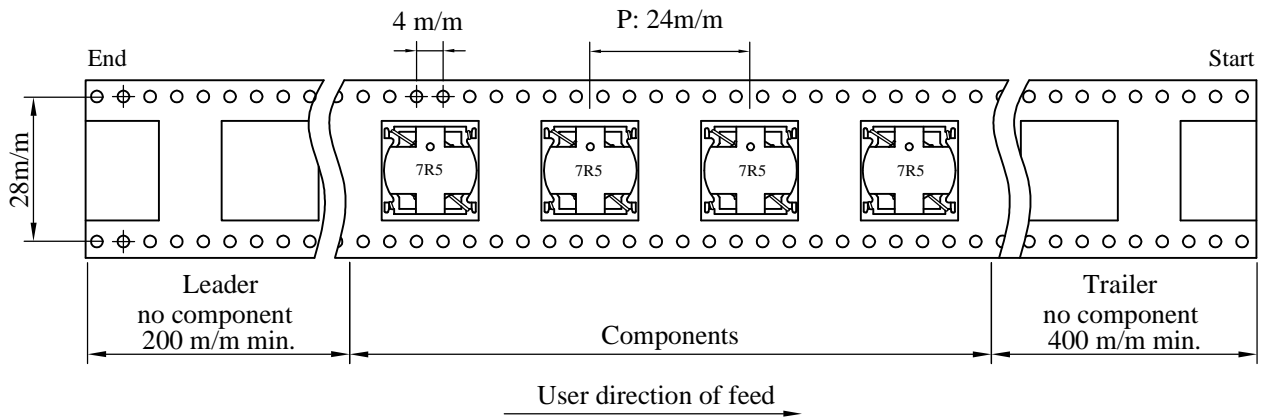

(2) Dimensions : (m/m)

Style	A	B	C	D	G	N	T
13 - 32	330	21±0.8	13±0.5	32	34 ⁺⁰	100 ⁻⁰	38.4

(3) Q'TY & G.W. Per package :

Code	Inner : Reel			Outer : Carton		
	Q'TY (pcs)	G.W. (gw)	Style	Q'TY (pcs)	G.W. (kg)	Size (cm)
B	200	800	13 - 32	800	5.0	38 x 37 x 22

AR-001C

SPECIFICATION FOR APPROVAL

REF. :

PROD. NAME	SMD Toroidal Power Filter	ABC'S DWG NO.	ST1510□□□□L□-□□□		
		REV.	20160427-C	PAGE	5

VI . Reliability test :

Item	Reference documents	Test Condition	Test Specification
1.High Temperature Exposure	MIL-STD-202 Method 108	1.Temperature: 125±2℃ 2.Time:96±2 hours.	1.No mechanical or electrical damage. 2.Inductance shall not change more than ±20%.
2.Temperature Cycling	JESD22-A 104	1.Temperature: -40℃ ~ +125℃ 2.Number of cycle:100 cycle 3.Dwell time:30 minutes	1.No mechanical or electrical damage. 2.Inductance shall not change more than ±20%.
3.Biased Humidity Test	MIL-STD-202 Method 103	1.Temperature : 85±2 ℃ 2.Humidity: 85% RH. 3.Time:96±2 Hours	1.No mechanical or electrical damage. 2.Inductance shall not change more than ±20%.
4.Operational Life	JESD22-A 108	1.Temperature: 125℃ (Temp. rise included) 2.Time:96±2 hours. 3.Rated current :	1.No mechanical or electrical damage. 2.Inductance shall not change more than ±20%.
5.External Visual	JESD22-B 101 & MIL-STD-883 Method 2009	Inspect product constructions, marking and workmanship.	1.No pollution on the surface of products. 2.Clear marking. 3.No crack.
6.Physical Dimensions	JESD22-B 100	Verify physical dimensions to the applicable product detail specification.	Per product specification standard
7.Resistance to solvents	MIL-STD-202 Method 215	Immerse into solvent for 3±0.5 minutes & brush 10 times for 3 cycles.	1.No body change in apperance. 2.No marking blurred. 3.Inductance shall not change more than ±20%.
8.Vibration Test	MIL-STD-202 Method 204	1.Frequency and Amplitued : 10-2000-10 Hz, 1.5 mm. 2.Direction:X, Y, Z 3.Test duration:2 hours for each direction, 6 hours in total.	1.No mechanical or electrical damage. 2.Inductance shall not change more than ±20%.
9.Resistance To Soldering Heat Test	MIL-STD-202 Method 210 & J-STD020D.1	1.Highest temperature : 245±5℃. 2.Time (temp. ≥ 217℃) : 60~150 Second. 3.IR reflow times : 3 times.	1.No mechanical or electrical damage. 2.Inductance shall not change more than ±20%.
10.Saturation Current	JIS C 6436 & User SPEC.	1.Applied rated current for 5 second. 2.Saturation current :	Inductance shall not drop more than 30% typ.
11.Over load	JIS C 6436 & User SPEC.	1.Applied one and half rated current for a period of 5 minutes. 2.Rated current :	No electrical or mechanical damage
12.Temperature Rise Current	JIS C 6436 & User SPEC.	1.Applied rated current for 10 minutes. 2.Temperature measure by digital surface thermometer. 3.Irms current :	Surface temperature rise is less than 40℃ typ.
13.Solderability Test	J-STD-002 & JESD22-B 102	1.Baking in pre-testing : 150±5℃ / 16Hours±30 min. 2.Peak temperature : 240±5℃ 3.Time (temp. ≥ 217℃) : 60~150 second. 4.IR reflow times : 1 times.	More than 95% soldering coverage min on terminations.
14.Electrical Characteriazation	MIL-STD-202 Method 304 & User SPEC.	1.Operating temperature : -40℃~125℃ 2.Room temperature : 25℃.	1.No mechanical or electrical damage. 2.Inductance shall not change more than ±20%.
15.Drop	CNS-C6354 & GB/T 2423.8	1.Products shall be mounted on SPEC. PCB and dropped down from a height of 1m 2.Drop total time : 6 time (Every side of sample drop 2 time)	1. Adhesion on PCB shall be enough. 2. Product appearance shall not break. 3. No electrical damage.
16.Terminal Strength Test	IEC 60068-2-21	1.Apply push force to samples mounted on PCB. 2.Force of 1.8 kg for 60±1 seconds.	After test, inductors shall be no mechanical damage.

AR-001C